

**CHATHAM AREA TRANSIT AUTHORITY RFP 2023-04, ADDENDUM NO. 2**

**DATE:** November 2, 2022  
**ORIGINAL IFB NUMBER:** 2023-04  
**PROJECT:** CAT Hybrid Ferry Vessels  
This Addendum forms a part of the Invitation for Bid 2023-04 dated, September 13, 2022.

**Additional Information for wheelchair and Propulsion Systems.**

Please see drawings attached to this addendum and information below for wheelchair.

The drawings originally showed the Lift-U LU-18 see below. This was redacted from the drawings.

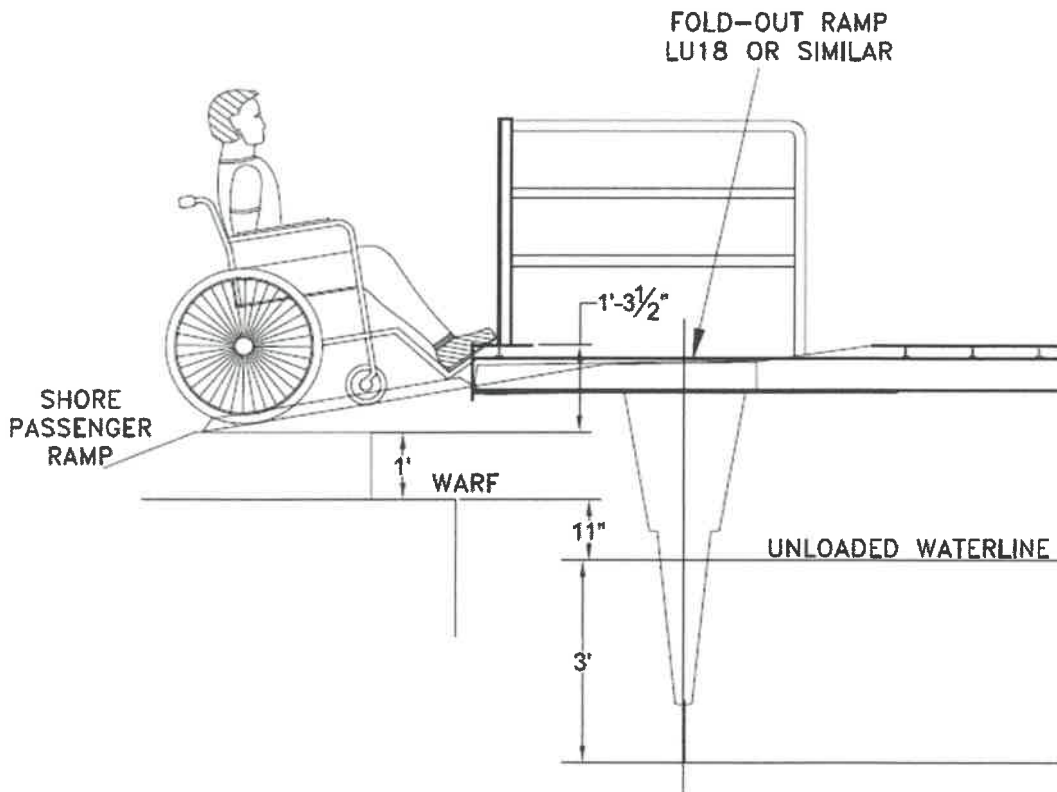

DeJong & Lebet Inc 1734 Emerson St Jacksonville, FL 32207 Telephone (904) 399-3673	Project # 22-1477	Vessel:	Orig Date: 6/29/2022
	Drawing # 1477-0228	Savannah Ferry (Diesel Hybrid)	Rev.0 Rev. Date: --
<b>HULL RESISTANCE AND PROPULSION - 0 to 15 kts</b>			

**TOTAL THRUST HORSEPOWER REQUIRED**  
1kt Wind and 1 kt Current

